

Take Control.
ION
StormPro®



BA33i+

Sump Pump With Built-In High Water Alarm

- Basement Sump
- Dewatering



37 Forestwood Dr., Romeoville, IL 60446 www.ionproducts.net [815] 886-9200

Patent No. 8,591,198

BA33i+

Sump Pump With Built-In High Water Alarm

System Specifications

Typical Applications	<ul style="list-style-type: none">• Basement sump• Dewatering
Maximum Capacity	Up to 68 GPM
Maximum Head	Up to 25'
Electrical Data	115 V, 1 Ø, 4.5 FLA, 60 Hz
Motor Data	1/2 HP, 3450 RPM
Recommended Minimum Basin Size	18" x 24"
Automatic Operation	i+: Ion+ (standard)
Materials of Construction	Cast iron & stainless steel
Impeller	Thermoplastic vortex
Power Cord	10' Standard
Discharge Size	1 1/2" NPT
Solids Handling	1/2"

Pump Dimensions

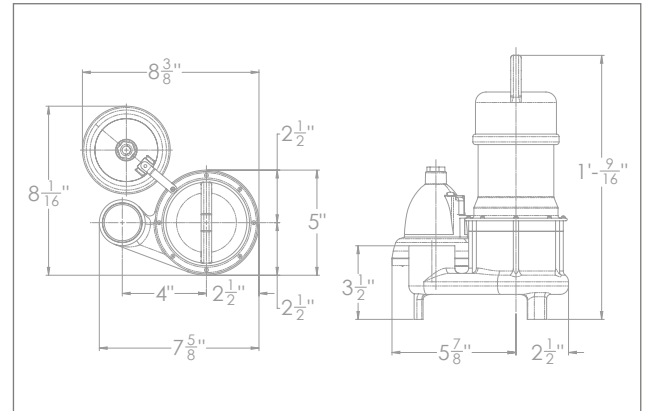

Pump Performance

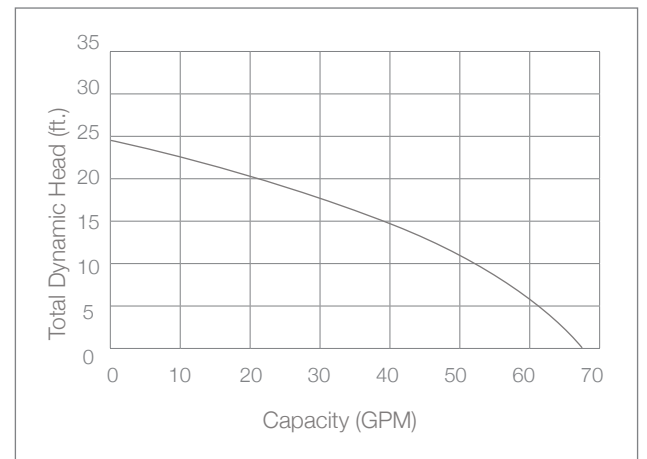

Features

- Energy efficient motor
- Carbon ceramic mechanical seal
- Thermal overload protection
- Piggyback Ion+® digital level control switch with alarm has no moving parts (standard)
- Stainless steel screen prevents debris from entering the pump
- 3 year warranty